

EX41922-T

Hardened Unmanaged 2-port 10/100/1000BASE PoE+2-port 100/1000 SFP Ethernet Switch

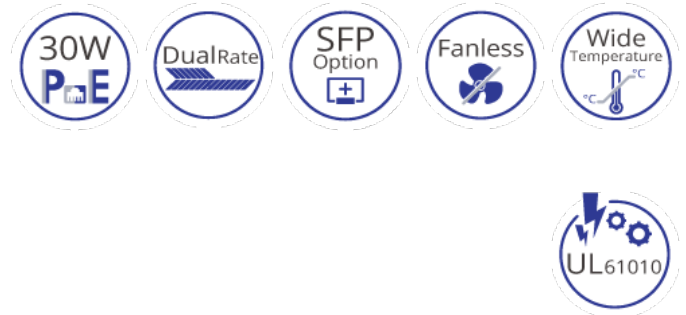

Overview

EtherWAN's EX41922 Series is a compact hardened unmanaged Gigabit switch, designed as an easily deployed platform for peripheral devices in harsh environments. It is a cost-effective option for surveillance systems in extreme climates.

The new EX41922-T is equipped with two 10/100/1000Base RJ-45 copper ports supporting Power over Ethernet (PoE), and two 100/1000Base SFP fiber optic slots for long distance connectivity. The two uplink SFP interfaces provide 100 or 1000SFP speed, selected by DIP switch. They can be used in a daisy chain formation, and are compatible with the proprietary Alpha-chain redundancy protocol when used with a compatible EtherWAN managed switch. Moreover, EX41922-T provides up to 30 Watts PoE per port with a total power budget of 60 Watts. Although unmanaged, the EX41922-T is feature-rich with 10K Jumbo Frame support, full wire speed Gigabit throughput, QoS support, and eco-friendly IEEE802.3az EEE (Energy Efficient Ethernet) compliance. With its hardened specifications, high performance, and energy efficiency, the EX41922-T is a flexible and reliable solution for extended networks.

EtherWAN — "When Connectivity is Crucial."

Spotlight

Hardened Grade

- » Supports -40 to 75°C (-40 to 167°F) operating temperature
- » Redundant power inputs on terminal block connector
- » Supports DIN-Rail mounting

Fiber Connectivity

- » Up to two 1000BASE SFP ports for daisy chain or Alpha-chain applications
- » Provides 100BASE or 1000BASE SFP by DIP switch

Port Failure Alarm

- » Provide relay alarm to notify users when power fails or link down occurs by DIP switch

Full Gigabit bandwidth and Jumbo frame

- » Gigabit wire-speed transmission for bandwidth-demanding application
- » Jumbo frame up to 10K bytes to increase throughput and transmission efficiency

Specifications

Technology

Standards

- IEEE802.3 10BASE-T
- IEEE802.3u 100BASE-TX/100BASE-FX
- IEEE802.3ab 1000BASE-T
- IEEE802.3z 1000BASE-SX/1000BASE-LX
- IEEE802.1x, Full duplex flow control
- IEEE802.1az Energy Efficient Ethernet
- IEEE802.3af/at Power over Ethernet (PoE)

Forward and Filtering Rate

- 14,880pps for 10Mbps
- 148,810pps for 100Mbps
- 1,488,100pps for 1000Mbps

Packet Buffer Memory

- 1MB

Processing Type

- Store-and-Forward
- Auto Negotiation
- Half-duplex back-pressure and IEEE802.3x full-duplex flow control
- Auto MDI/MDIX

Jumbo Frame

- 10K bytes

Address Table Size

- 8K MAC addresses

Power

Input Voltage

- Redundant power inputs; Terminal Block: 52–57VDC for PoE

Power Consumption

- 63.6W@52VDC, 63.8W@57VDC
- PoE Power budget: 60W

Power Technology

- Alternative A
- Pins 1/2(+), 3/6(-)

Mechanical

Casing

- Metal case
- IP30

Dimensions

- 42 x 90 x 100mm (W x D x H)
(1.65" x 3.54" x 3.93")

Weight

- 0.37Kg (0.82lb)

Installation

- DIN-Rail

Interface

Ethernet Ports

- 10/100/1000BASE-T: 2 ports
- 100/1000BASE SFP: 2 ports

LED Indicators

- Per Unit: Power1 (Green), Power2 (Green), Alarm (Red)
- Per Port: Link & Activity (Green)
- Per PoE Port: PoE (Amber)

DIP Switches

- Enable/Disable Port fault alarm, SFP port on 100BASE

Alarm Contact

- One relay output with current 0.5A/48VDC
 - Supports normal close and normal open
-

Environment

Operating Temperature

- -40 to 75°C (-40 to 167°F)

Storage Temperature

- -40 to 85°C (-40 to 185°F)

Ambient Relative Humidity

- 5% to 95% (non-condensing)
-

Regulatory Approvals

ISO

- Manufactured in an ISO 9001 facility

Safety

UL 61010

EMI

FCC Part 15B Class A

VCCI Class A

EN 61000-6-4

EMS

EN 61000-6-2

- EN 61000-4-2 (ESD Standards)
- EN 61000-4-3 (Radiated FRI Standards)
- EN 61000-4-4 (Burst Standards)
- EN 61000-4-5 (Surge Standards)
- EN 61000-4-6 (Induced RFI Standards)
- EN 61000-4-8 (Magnetic Field Standards)

Environmental Test Compliances

IEC 60068-2-6 Fc (Vibration)

IEC 60068-2-27 Ea (Shock)

FED STD 101C Method 5007.1 (Free fall w/ package)

Application

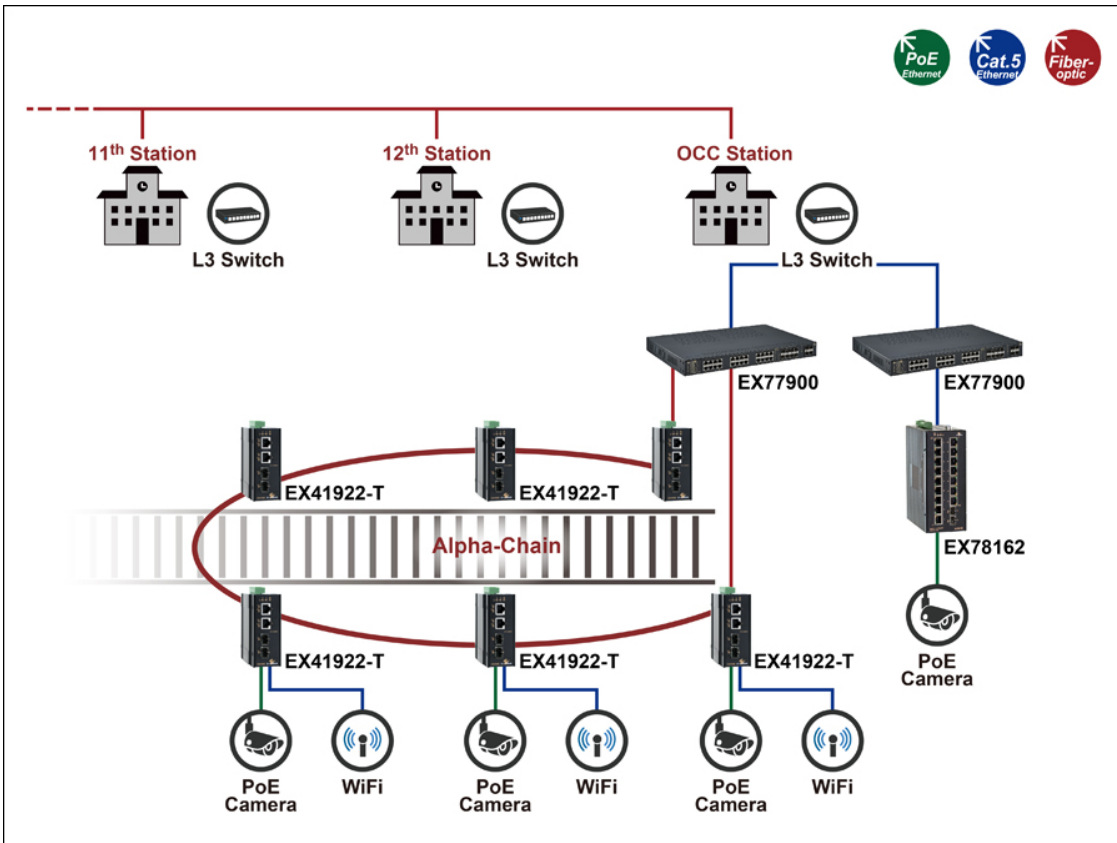

Dimensions

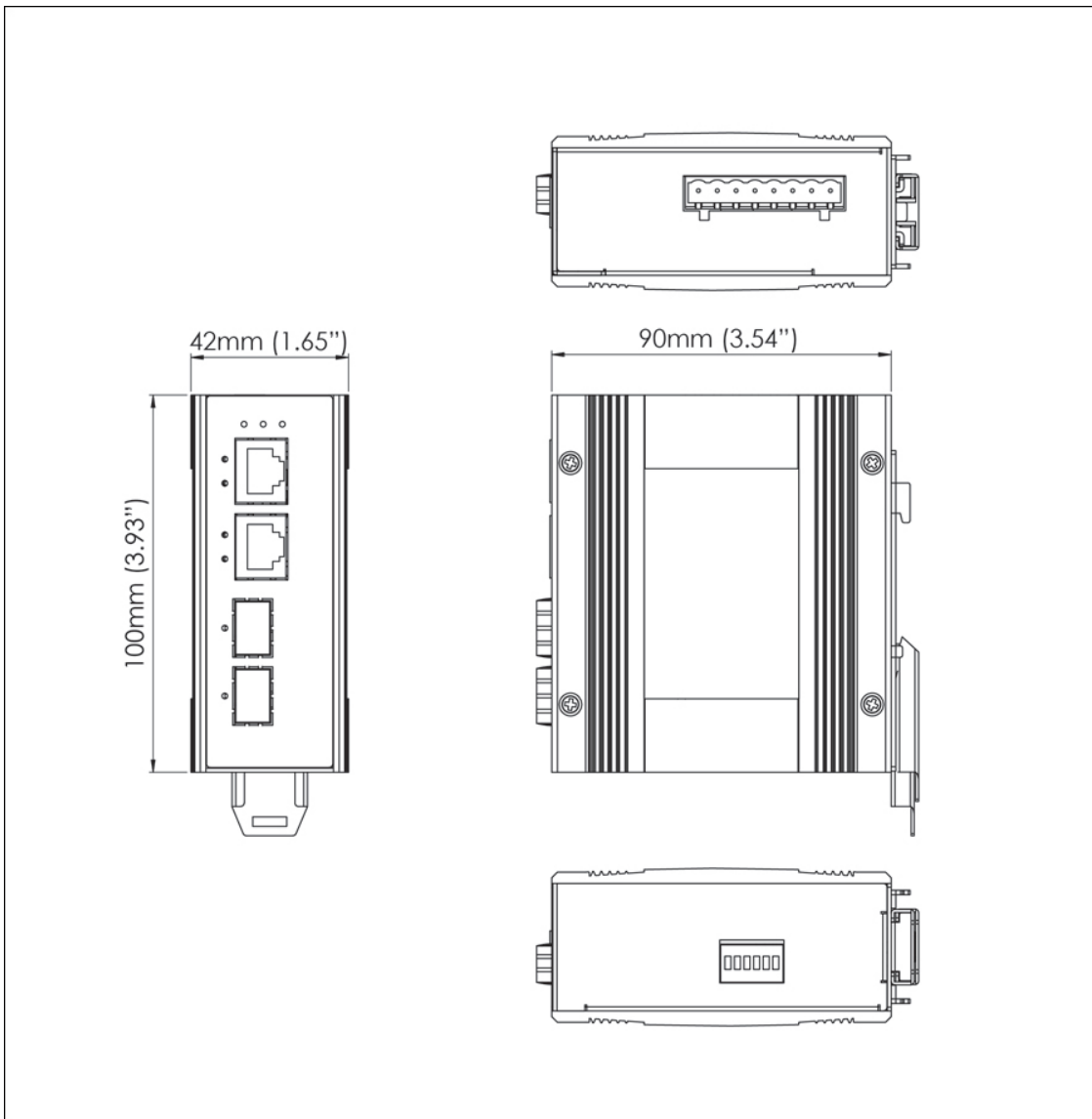

Ordering Info

Model

EX41922-T	2-port 10/100/1000Base-T PoE+2-port 100/1000 SFP Hardened Unmanaged Ethernet Switch
------------------	---

* DIN-Rail mounting kit included



© EtherWAN Systems, Inc. All rights reserved. 20250212

EtherWAN is constantly developing and improving products. Specifications are subject to change without notice and without incurring any obligation.