

EL1142 系列

IEC 61850/IEEE 1613 強固級 2埠10/100BASE-TX +2埠100BASE-FX 光電轉換器



產品介紹

EL1142系列具備2組獨立10/100BASE-T網路埠和2個100BASE-SX-LX光纖埠，有效整合不同介面傳輸，支援2個獨立光電轉換器路徑，在空間有限的應用環境中更具安裝彈性。

EL1142 符合IEC 61850-3/IEEE 1613相容認證，抗電磁干擾設計，適用於變電站、電力整合等應用市場，支援Link-Fault-Pass-Through (LFPT)自動斷開故障連結，避免封包持續傳送，快速偵測到網路連線的錯誤。

EtherWAN — "When Connectivity is Crucial."

產品亮點

高密度埠距

- » 在精巧機體中提供兩個獨立的光電轉換器路徑

符合IEC 61850-3/IEEE 1613認證

- » 符合變電站自動化所需之應用標準

符合EN 50121-4認證

- » 專為軌道環境應用設計及測試

支援Link-Fault-Pass-Through (LFPT)

- » 針對光電轉換器連線狀態提供持續的監控
- » 當連線的其中一端中斷，另一端仍然繼續傳輸封包，然後等待已經斷線的那一端重新連線啟動

產品規格

技術

標準

- IEEE 802.3 10BASE-T
- IEEE 802.3u 100BASE-TX/FX
- IEEE 802.3x Full-Duplex and flow control

Forward and Filtering Rate

- 14,880pps for 10Mbps
- 148,810pps for 100Mbps

緩衝記憶體封包

- 128K bits

傳輸型式

- Store-and-forward
 - Auto Negotiation
 - Half-Duplex back-pressure and IEEE 802.3x Full-Duplex flow control
 - Auto MDI/MDIX
-

電源

輸入電壓

- 12-48VDC (Terminal Block)

電力功耗

- 4.5W MAX. 0.37A@12VDC, 0.17A@24VDC, 0.09A@48VDC

Protection

- Overload current protection
 - Reverse polarity protection
-

機構

機殼

- Aluminum Case
- IP30

尺寸

- 50 x 110 x 135mm (W x D x H)
(1.97" x 4.33" x 5.31")

重量

- 1.2kg (2.64lbs.)

安裝方式

- DIN-Rail (top hat type 35mm) or panel mounting
-

介面

乙太網路埠

- 10/100BASE-TX: 2 ports
- 100BASE-FX: 2 ports

LED 指示燈號

- Per Unit: Power 1, Power 2, Alarm
- Per 10/100BASE-TX Port: Link/Activity, 100, Full-Duplex/Collision, LFPT
- Per 100BASE-FX Port: Link/Activity, Full-Duplex/Collision

Relay Contact

- Dry contact with current 0.6A/30VDC
-

環境

工作溫度

- -40 to 75°C (-40 to 167°F)

儲存溫度

- -40 to 85°C (-40 to 185°F)

工作濕度

- 5% to 95% (無凝結)
-

通過認證

ISO

- Manufactured in an ISO 9001 facility

Safety

UL 61010

EMC

FCC Part 15B Class A

VCCI Class A

EN 61000-6-4

EN 61000-6-2 Class A

EN 55032 Class A

EMS

EN 61000-6-2

- EN 61000-4-2 (ESD Standards)
- EN 61000-4-3 (Radiated RFI Standards)
- EN 61000-4-4 (Burst Standards)
- EN 61000-4-5 (Surge Standards)
- EN 61000-4-6 (Induced RFI Standards)
- EN 61000-4-8 (Magnetic Field Standards)

Environmental Test Compliance

IEC 60068-2-6 Fc (Vibration Resistance)

IEC 60068-2-27 Ea (Shock)

FED STD 101C Method 5007.1 (Free fall w/package)

Industrial Compliance

IEC 61850-3/IEEE 1613

EN 50121-4

產品應用圖

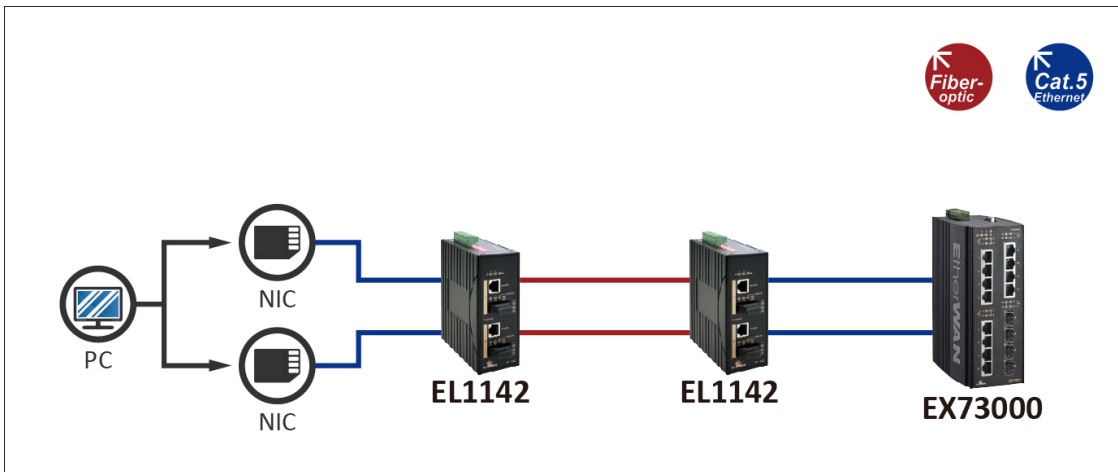
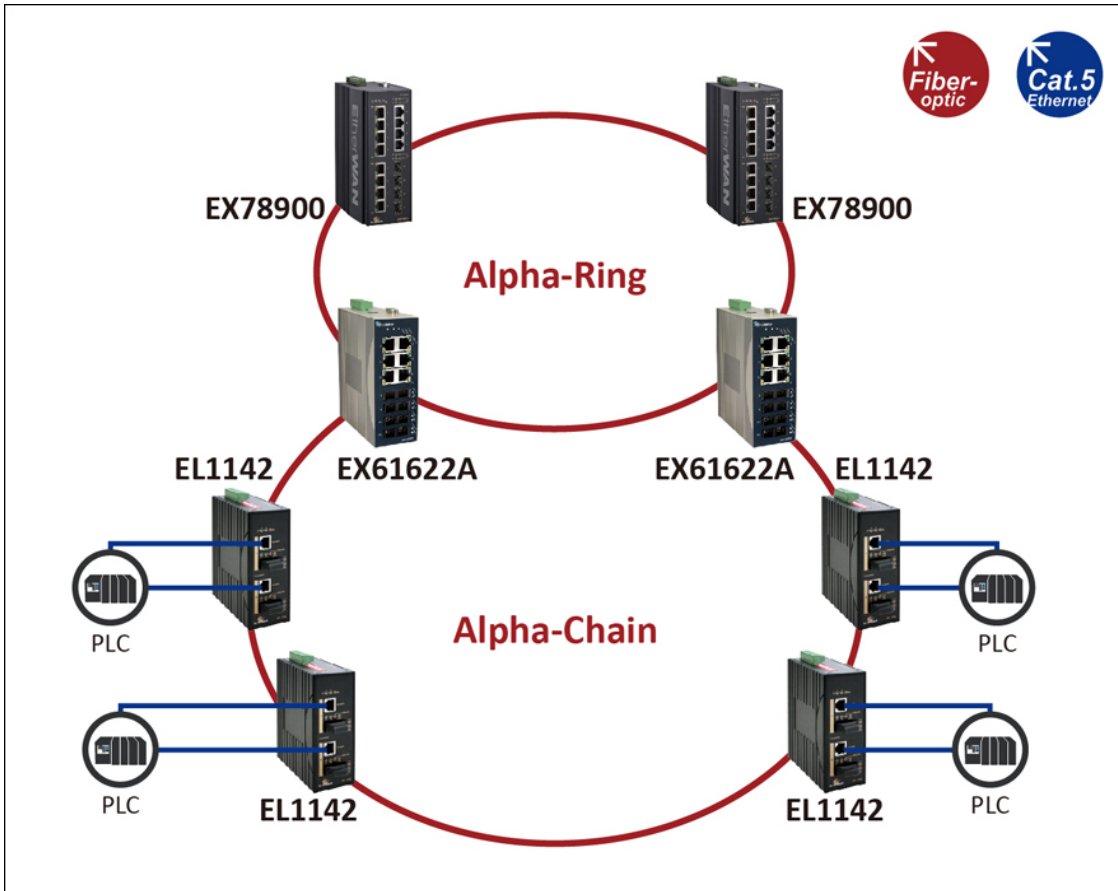

產品尺寸圖

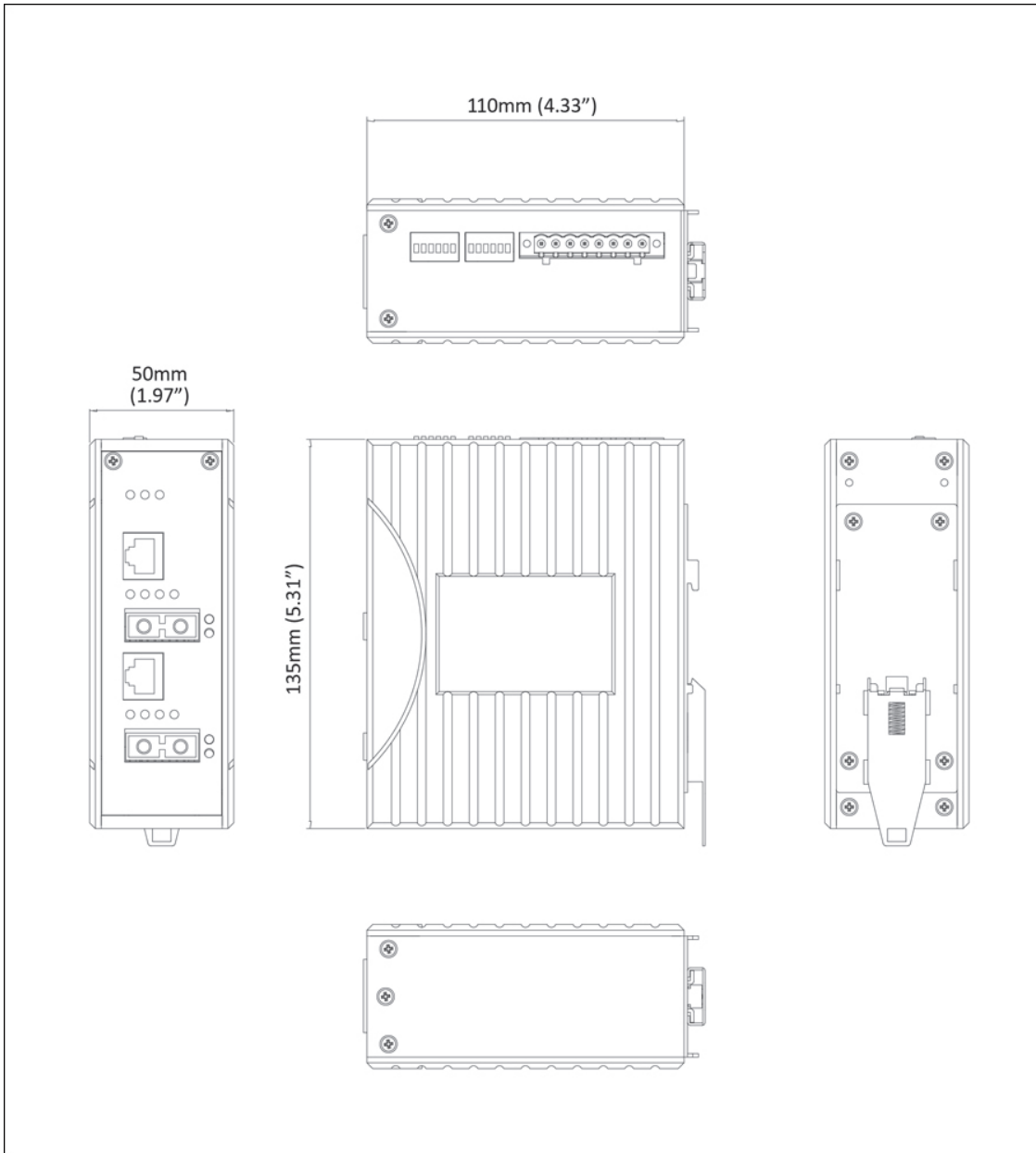

訂購型號

型號

EL1142-X0B	2-Port 10/100BASE-TX +2-Port 100BASE-FX IEC 61850-3/IEEE 1613 Hardened Media Converter
-------------------	--

* DIN-Rail mounting kit included.

100BASE-X Fiber Options (X)

1	Multi Mode (SC) - 2Km (1310nm)
2	Multi Mode (ST) - 2Km (1310nm)
A	Single Mode (SC) - 20Km (1310nm)
B	Single Mode (SC) - 40Km (1310nm)
H	Single Mode (ST) - 20Km (1310nm)

Optional Accessories

KP-AA96-480	KP-AA96-480 Panel mounting kit
HDR-30-24	30W/1.5A DIN-Rail 24VDC Industrial Power Supply
HDR-60-24	60W/2.5A DIN-Rail 24VDC Industrial Power Supply
EDR-75-24	75W/3.2A DIN-Rail 24VDC Industrial Power Supply
EDR-120-24	120W/5A DIN-Rail 24VDC Industrial Power Supply
EX41-145046-X	Power Supply 45W 12VDC with Open Wire (X) = 1: US, 2: EU, 3: UK, 4: AU, 5: JP, 6: SA

